

Swimming Pools SP 02 | Swimming pool barriers and other requirements

Audience

The audience/s for this Practice Note include/s:

- | | |
|---|--|
| <input checked="" type="checkbox"/> Architects/ Designers | <input checked="" type="checkbox"/> Owner Builders |
| <input checked="" type="checkbox"/> Builders | <input checked="" type="checkbox"/> Plumbers |
| <input checked="" type="checkbox"/> Building Surveyors/ Inspectors | <input type="checkbox"/> Real estate management agents |
| <input type="checkbox"/> Engineers | <input checked="" type="checkbox"/> Trades and Maintenance (inc. Electricians) |
| <input checked="" type="checkbox"/> Home Owners / Residential Tenants | |

Purpose

The purpose of this Practice Note is to provide guidance and technical advice on the design and construction of swimming pool safety barriers and additional NCC compliance requirements for swimming pools.

The content below provides guidance on:

- Swimming pool barriers
- Buildings forming part of a barrier
- Barrier design considerations
- Outdoor swimming pools
- Energy efficiency
- Plumbing work
- Electrical considerations



For further information on swimming pool barriers and safety requirements, please refer to Building Practice Note SP-01: Swimming pool standards and safety requirements.

Abbreviations & Definitions

The abbreviations and definitions set out below are for guidance only. They are not intended to vary those set out in the Building Act 1993, the Building Regulations 2018 or the National Construction Code.

- **AS** – Australian Standard
- **Act** – Building Act 1993



- **Barrier** – Assembly of components, natural or otherwise, that restricts access to the pool. The barrier includes fences, posts and panels, gate units, gates and door sets, constructed or natural walls (retaining or otherwise), sides of buildings, and balustrades on a balcony where they form part of intended barrier.
- **Barrier Height** – Height of the barrier perpendicular to the finished ground level.
- **Barrier Standard** – Australian Standard AS 1926.1-2012 (Swimming pool safety Part 1: Safety barriers for swimming pools).
- **Boundary Barrier** – a dividing barrier between two adjoining properties
- **Chamfered Battens** – A triangular element of a barrier which is angled so the pool/spa barrier can't be climbed
- **FGL** – Finished Ground Level or permanent stable surface.
- **NCC** – National Construction Code 2022
- **NCZ** – Non-Climbable Zone which is a zone on a barrier and in the space adjacent to a barrier, running full length of a barrier including a gate, intended to restrict climbing of the barrier by young children.
- **Permanent Barrier** – Barrier or part of a barrier which cannot be removed without the use of tools, as set out by the barrier standard in AS1926.1.
- **Swimming Pool area** – the area that contains the pool or spa and is enclosed by a barrier.
- **RBS** – Relevant Building Surveyor
- **Regulations** – Building Regulations 2018
- **Site Fence** – Any permanent fencing on property boundaries as well as temporary fencing used during the construction period.
- **Swimming Pool** – Any excavation or structure (including a spa or a relocatable structure) that is capable of containing water to a depth of greater than 300mm, and principally used (or is designed, manufactured or adapted to be principally used) for swimming, wading, paddling, bathing or similar activities.
- **Young Child** – a child under the age of five years.

Swimming Pool Barriers

The outdoor swimming pool area must be a separate area enclosed by a barrier. Access into the swimming pool area must not be directly available via a door from a building.



Note: The total enclosure of the property is not considered sufficient in meeting the safety barrier requirements.

Internal Barrier

The swimming pools barrier standard AS1926.1 – 2012 nominates 5 Non-Climbable Zones (NCZ's). NCZ 1 to NCZ 4 apply to internal barrier where the barrier height is less than 1800mm – (Figure 2.1 AS1926.1 – 2012). NCZ 5 applies to where a boundary fence acts as a barrier to a swimming pool and has a height of not less than 1800mm on the inside.

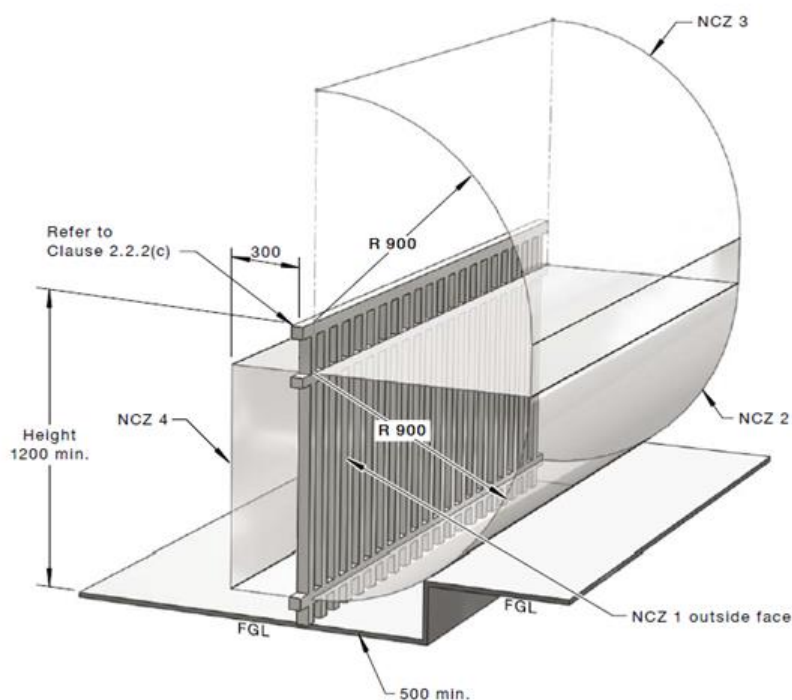

Figure 1 - Example of Non-Climbable Zones, *referenced from AS1926.1, Figure 2.1*

Reproduced with permission of Standards Australia Limited. Copyright in AS/NZS:2012 vests in Standards Australia Limited and Standards New Zealand.

The following is a summary of the requirements of each NCZ for internal and boundary barriers. Further requirements are located in the swimming pools barrier Standard.

- NCZ 1 - 900mm vertical plane on the outside of the internal barrier. This can be located anywhere within the perpendicular height of the barrier or anywhere between horizontal components including handholds and footholds.
- NCZ 2 – Is a quadrant created by a 900 mm radius from the top of NCZ 1 one. NCZ 2 is always immediately adjacent to NCZ 1 on all barrier.
- NCZ 3 – Is a quadrant created by a 900mm radius from the top of the barrier and applies to the outside of the barrier. Where NCZ 1 is below the top of a barrier, NCZ 3 extends vertically down from NCZ 1.
- NCZ 4 – Is applicable to all barriers with vertical openings 10 – 100mm in width. It is rectangular space that is 900 mm high by 300 mm deep and located on the inside of the barrier and aligns with NCZ 1.
- NCZ 5 – Is a quadrant created by a 900mm radius down from the top of the inside of a boundary barrier.
- NCZ 5 is only applicable to Boundary Barrier – See Boundary barrier and intersecting internal barriers Section.

Where the internal barrier (a barrier other than a boundary barrier) is 1800 mm or greater in height, the barrier does not require an NCZ and may be climbable on both sides.



Boundary Barrier

A boundary fence shall have a height of not less than 1800mm on the inside and NCZ 5 down from the top of the inside of the barrier, when it acts as a barrier to a pool as depicted in Figure 2.

Further requirements for boundary barrier are provided in the swimming pool barrier Standard

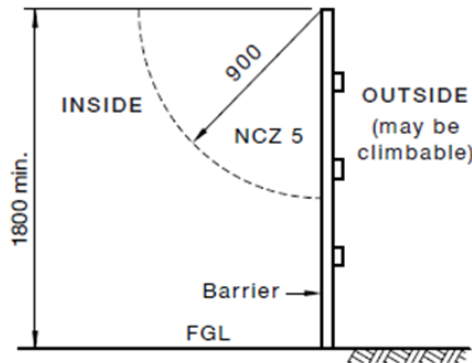

(a) Boundary barrier 1800 mm min.

Figure 2: Boundary barrier of 1800 mm min, referenced from AS1926.1, Figure 2.2

(Reproduced with permission of Standards Australia Limited. Copyright in AS/NZS:2012 vests in Standards Australia Limited and Standards New Zealand)

The location of the NCZ inside the swimming pool area means that it can be maintained by the pool owner or occupier.

Where NCZ 5 of a boundary fence intersects with a compliant internal fence, the following requirements apply (refer to Figure 3).

- The width of the top rail of surface of the intersecting barrier is not more than 50mm wide at any point within the NCZ, and
- intersects at an angle of between 45 and 135 degrees at the 1800mm boundary

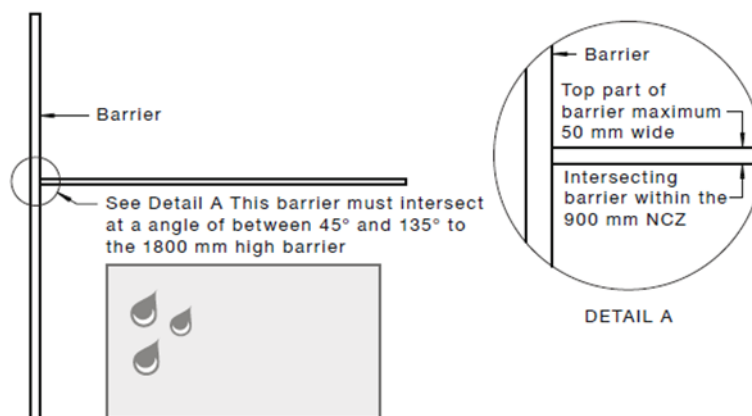

(b) Intersecting barrier with top less than 50 mm in width

Figure 3: Intersecting barrier with top less than 50 mm in width, referenced from AS1926.1, Figure 2.2(b)

(Reproduced with permission of Standards Australia Limited. Copyright in AS/NZS:2012 vests in Standards Australia Limited and Standards New Zealand)

Where the top surface or rail of the intersecting internal barrier exceeds 50 mm in width, the height of the lower barrier must be increased to a minimum of 1800 mm and extend not less than 900 mm from the intersection of the boundary fence - Refer to Figure 4.

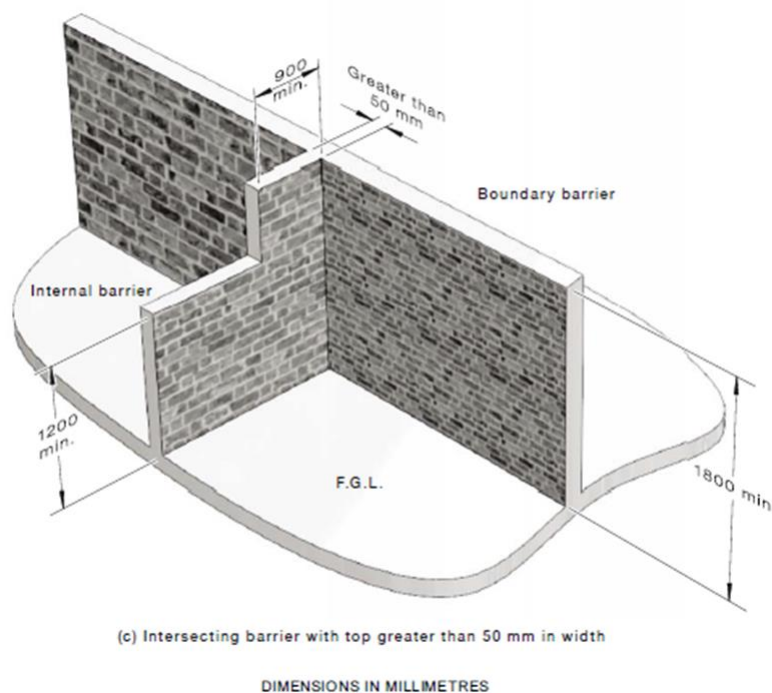

Figure 4: Intersecting barrier with top greater than 50mm in width, referenced from AS1926.1, Figure 2.2(b)
Reproduced with permission of Standards Australia Limited. Copyright in AS/NZS:2012 vests in Standards Australia Limited and Standards New Zealand.

Scenario

Figure 5 provides the requirements for various intersecting sections of internal and boundary barriers. Furthermore, it provides the application of NCZ when a building forms part of the swimming pool barrier.

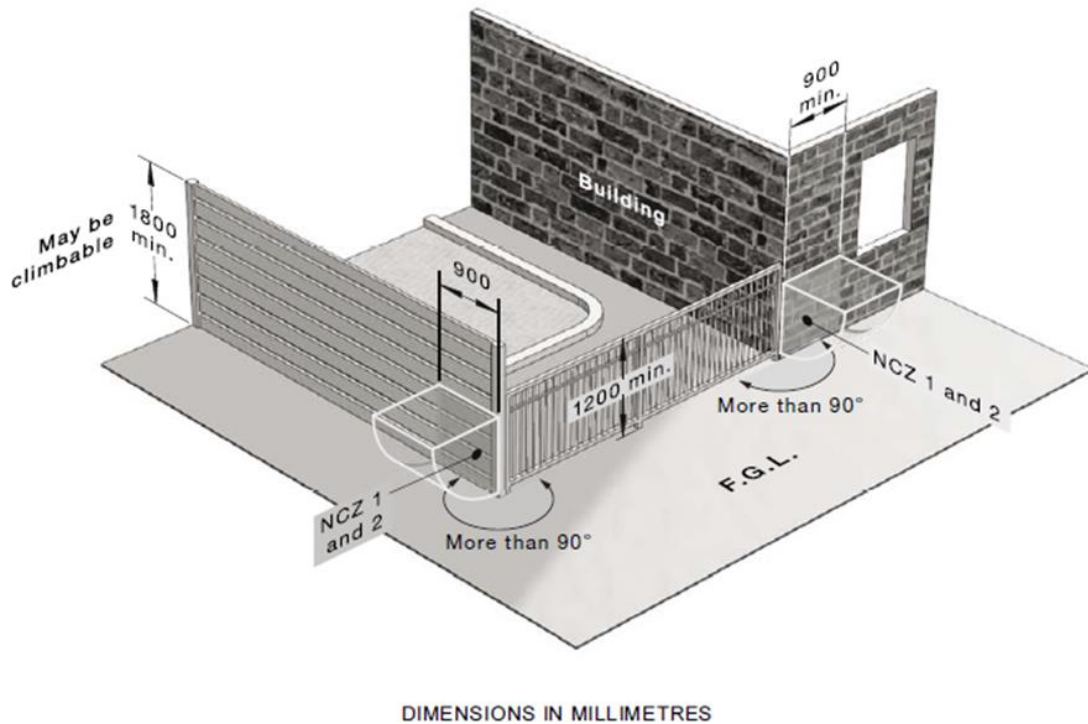

Figure 5: Intersecting internal barriers, referenced from AS1926.1, Figure 2.3
 Reproduced with permission of Standards Australia Limited. Copyright in AS/NZS:2012 vests in Standards Australia Limited and Standards New Zealand.

Glass Barriers

Glass in barriers must comply with the provisions of AS 1288-2006. Glass used in and around swimming pool areas that may generate a high risk of breakage from human impact must be Grade A safety glazing, with a minimum thickness as prescribed by AS 1288. Figure 6 provides the requirements for a glass gate with pivot hinges.

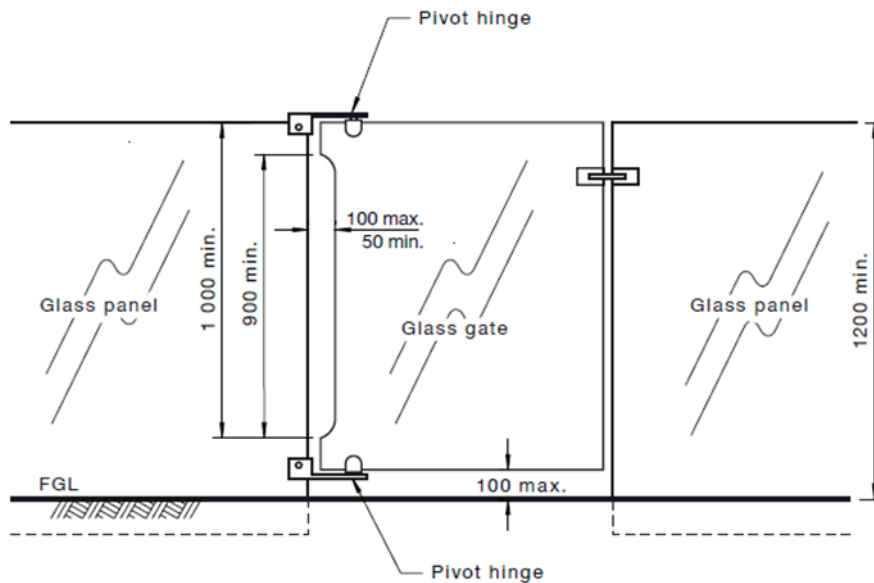

Figure 6: Glass gate with pivot hinges, referenced from AS1926.1, Figure 2.4
 Reproduced with permission of Standards Australia Limited. Copyright in AS/NZS:2012 vests in Standards Australia Limited and Standards New Zealand.



Steps abutting a barrier

A step, object or level change that abuts the barrier is considered the finished ground level and therefore the 1200 mm must be measured to this point. Clause 2.3.1 of AS 1926.1 requires that steps, objects or level changes must be set back a minimum of 500 mm from the barrier - Refer to Figure 1: Examples of Non-Climbable Zones. Clause 2.3.1 does not apply to boundary barriers.



This clause also applies to the boundary barrier within the swimming pool area and not on the adjoining property.

Building Forming Part of a Barrier

Garage Doors

The use of automatic closing roller doors or manual slide-bolting of roller doors in the closed position of garages are not an appropriate solution for compliance. The likelihood that a roller door will be left unbolted is an unacceptable risk.

AS 1926.1 2012 requires that the barrier must be a permanent structure. The definition of permanent structure is “A barrier or part of a barrier which cannot be removed without the use of tools”.

External Structures

External structures could include gazebos, pool houses and parts of Class 1 structures within the swimming pool area or forming part of the barrier. Owners, designers and building surveyors need to carefully consider the location of these structures within the swimming pool area or where they form part of the barrier.

In accordance with AS 1926.2-2007, tool sheds, garages, barbeques and enclosed non-habitable buildings should be located outside the swimming pool area. This is to reduce the likelihood of self-closing gates being propped open to gain access to those buildings. The risk that a child may be hidden by or within a structure is considerable, reducing the ability to adequately supervise children within the swimming pool area.

Enclosed buildings/structures that contain habitable rooms such as kitchens, playrooms, change rooms, or entertainment rooms located within and opening directly into the swimming pool area are required to be separated from the swimming pool area with a barrier. These buildings/structures can reduce or prohibit supervision within the swimming pool area, compromising the safety of children.

An open-sided gazebo or other open-shade structures supported by posts only are not considered to substantially reduce visibility within the swimming pool area, and may be constructed, wholly or partially without being separated by a barrier.

Plants

In accordance with AS 1926.1-2012, the barrier standard requires that within NCZs, there shall be no plants that will facilitate climbing. A plant does not facilitate climbing if it does not act as a foothold or handhold.

It is the responsibility of the property owner to make sure the barrier restricting access to the swimming pool is properly maintained. This includes maintenance of the adjacent vegetation, which can adversely affect the effectiveness of the barrier.



The barrier standard does not permit objects (for example, raised garden beds, pots, other landscaping features, and so on) that would reduce the height of a barrier, to be within 500 mm of a barrier. Although not directly mentioned, plants can be within 500 mm of a barrier if they will not reasonably support the weight of a young child.

Barrier Design Considerations

Single Footing for Posts and Gates

A common issue with barriers is the spreading of posts supporting the gate and latches if on separate footings. Over time, this has the effect of not allowing the gate to latch properly and causing it to swing freely between the posts.

It is recommended that the footings for fence posts are poured monolithically, or as one footing across the opening. This would ensure the posts are connected and supporting the gate and latches. As the ground moves, the posts would move, reducing spreading and ensuring that the gate will continue to self-latch.

Perforated Materials

A barrier (not on the property boundary) consisting of perforated or mesh materials with apertures of the mesh not greater than 13 mm, must be a minimum of 1200 mm in height and have an NCZ in accordance with Clause 2.2 of AS 1926.1- 2012.

Barriers using material with apertures more than 13 mm but not greater than 100 mm, must have a minimum height of 1800 mm. Any material with apertures greater than 100 mm shall not be used. Barriers of perforated or mesh materials must be of sufficient height so that a 25 kg weight supported at any point along the top of the barrier, will not reduce the height to less than 1200 mm.

The bottom of the barrier must be installed in such a manner that the gap at the bottom must not exceed 100 mm when applied with a vertical lift force of 100 N (Newtons).



All measurements of openings in perforated material or mesh are measured horizontally across the widest part.

Projections and Indentations

Projections and indentations within an NCZ1 should not be climbable. Horizontal surfaces with a depth greater than 10 mm should not be less than 900 mm from the top of the barrier, and less than 900 mm above the finished ground level. (Refer to Figure 7).

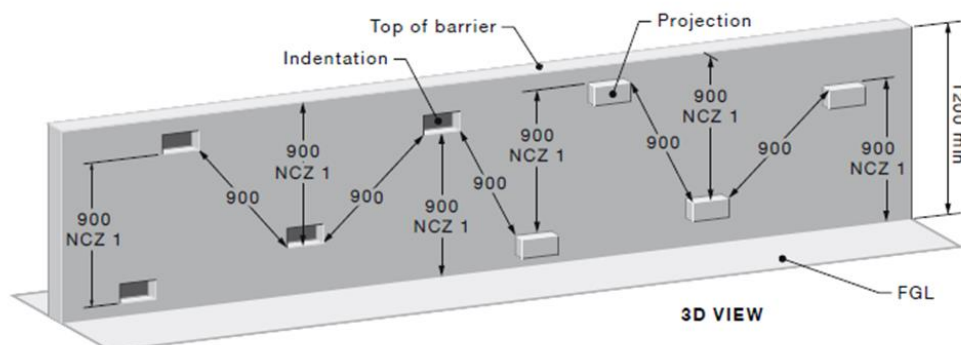

Figure 7: Barrier with projections and indentations greater than 10mm, referenced from AS1926.1, Figure 2.5

Reproduced with permission of Standards Australia Limited. Copyright in AS/NZS:2012 vests in Standards Australia Limited and Standards New Zealand.



Horizontal components not acting as a hold for climbing

Chamfered battens that have a minimum 60-degree (to the horizontal) slope are permitted to be used on barriers less than 1800 mm in height – Refer to Figure 8. These battens are an effective means for making a horizontal element non-climbable.

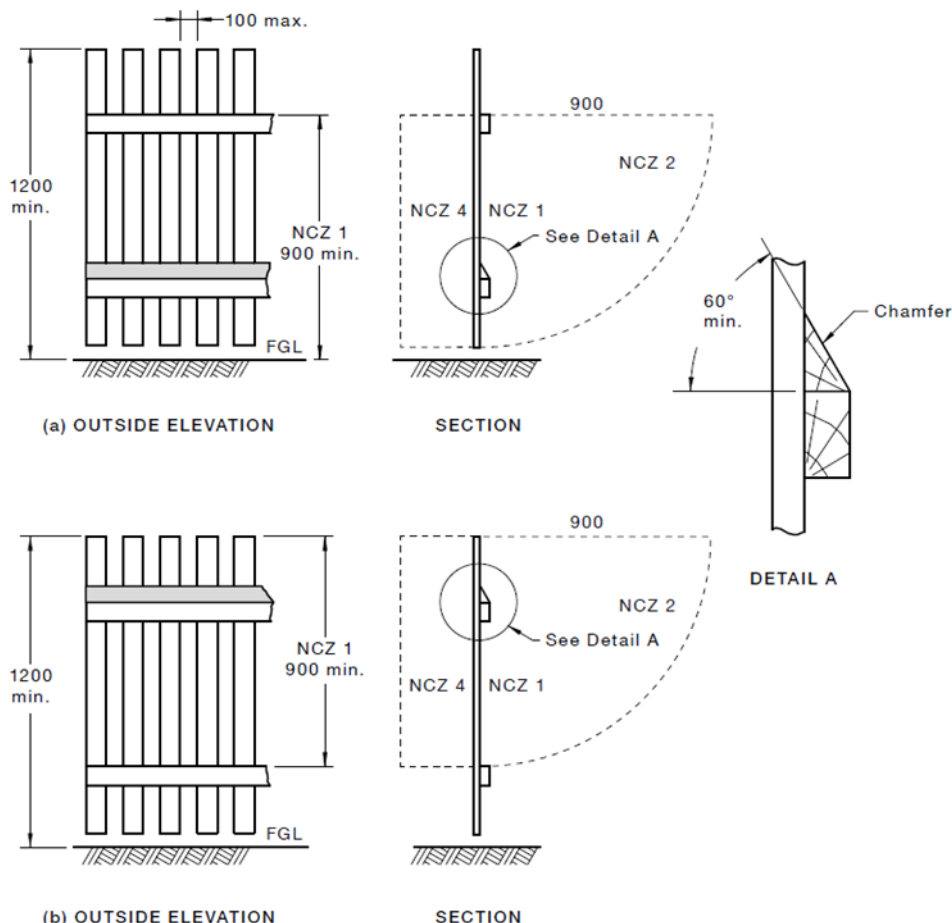

Figure 8: Horizontal components not acting as a hold for climbing, referenced from AS1926.1, Figure 2.6

Reproduced with permission of Standards Australia Limited. Copyright in AS/NZS:2012 vests in Standards Australia Limited and Standards New Zealand.



Such a solution is not recommended for a boundary paling fence. The lapped palings provide a gap greater than 10 mm at the horizontal rails which can create a handhold for young children. This gap will also be required to be filled in and be non-climbable. Any solution should take into consideration the potential movement of the barrier due to weathering.

Above Ground Swimming Pool Barrier

The wall of an above-ground swimming pool can form part of a barrier provided it is a minimum 1.2 m high above the finished ground level and is non-climbable.

An above-ground swimming pool does require a barrier to protect the ladder access, the pump and filter. The barrier must be 300 mm clear of any part of the ladder, pump, filter or any other climbable object if the barrier has openings between 10mm and 100 mm wide.



Fibreglass Swimming Pool Barrier

Where a fibreglass shell swimming pool is placed within an excavation and is required to be filled with water, as part of the construction requirements, the swimming pool area must have a barrier complying with AS1926.1-2012 in place immediately after the swimming pool is filled.

Indoor Swimming Pools

Swimming Pools are considered 'indoors' when fully enclosed by walls on all sides and roofed, and access to the swimming pool area is from within the building that contains the swimming pool. The design drawings need to clearly show details of the barrier, child-resistant door sets and the swing direction of doors as part of the building permit application.

For indoor swimming pools, a side-hung door within the dwelling may be used. The door forming part of a barrier must swing away from the swimming pool area when opening. It must also be self-closing and self-latching in accordance with the requirements of AS1926.1-2012 and have a NCZ 1 located to the outside of the door. A self-closing and self-latching sliding door may also be used.



Swimming pools under verandas or within an enclosure, open to the elements on any side (not including windows in walls) are considered 'outdoor' pools. Child-resistant door sets must not be used for access from the dwelling.

Outdoor Pools

Doorsets

AS1926.1 -2012 Clause 2.7 specifies that child-resistant doorsets can only be installed to access indoor swimming pools and the indoor part of an indoor/outdoor swimming pool. Doors from a building (house, garage, shed, pool house, and so on) to an outside swimming pool cannot be used to allow direct access to the swimming pool area. A separate barrier between the building and the swimming pool area is required.

Barrier Access

Where there is an existing door, it must have a compliant barrier and gate constructed around it or must be either removed and replaced with a child-resistant window or be altered to make the door unopenable. This means the door is screwed, bolted or fixed to the door frame using fixings that cannot be removed. Screws should be non-removable, and bolts should have lockable nuts. However, walls of buildings and child-resistant windows can still be used as part of the barrier.

Water Reticulation

Designers and builders of swimming pools should be aware of the requirement for performance-based testing of system elements to eliminate the risk of entrapment. In using AS1926.3-2010, pool designers need to provide the RBS with the design and test data from the manufacturer of the main drain cover. The RBS will need to ensure that the main drain cover has been installed in accordance with the building permit documentation and AS1926.3-2010 where appropriate.

The following information should be provided to the RBS to determine if the proposed work complies:

- Detailed drawings of the recirculation and filtration system, showing the location of all suction points including solar suction.
- Demonstrate that the suction points will not be less than 600 mm apart.
- Details of the active main drain and outlet covers, or a note that outlet covers when installed will be marked as tested in accordance with AS1926.3 – 2010 (Appendix A - Outlet Cover Tests).



Energy Efficiency

The NCC Volume One J8D3 and J8D4 NCC Volume Two VIC H6D2 (Victorian Variation) and NCC Housing Provisions Standard 13.7.8 and 13.7.9 specify the energy efficiency requirements for swimming pools.

Heating of a swimming pool (other than a spa) or a spa that shares a reticulation system with a swimming pool, may be by either of the following:

- Solar heater (not boosted by electric resistance heating for swimming pools associated with Class 1 buildings).
- Heater using reclaimed energy or heat from another process.
- Geothermal heater (only for Class 2-9 buildings).
- Gas heater.
- Heat pump.
- A combination of the above.

A swimming pool (or spa pool having a capacity of 680 litres or more) must also be provided time switch to control the operation of the heater, and a time-switch to control the operation of the circulation pump. The time-switch must be capable of switching electric power on and off at varied pre-programmed times and on variable pre-programmed days for Class 2-9 buildings.

All swimming and spa pools must be provided with a cover where a gas heater or heat pump is used to heat the water. All pipework that carries heated and chilled water for a swimming or spa pool in a Class 2-9 building must be insulated.



From 1 May 2023 to 30 September 2023 Section J of NCC 2019 Volume One Amendment 1 may apply instead of Section J of NCC 2022 Volume One. From 1 October 2023 Section J of NCC 2022 Volume One applies.

Plumbing Work

The designs of the swimming pool recirculation and filtration systems are required to be provided to the RBS as part of the building permit application.

The Plumbing Regulations 2018 do not define the swimming pool recirculation and filtration piping system or the associated pump and filters as regulated plumbing work, therefore the work does not need to be undertaken, or signed-off by a licensed plumber. However, the connection of pool backwash piping made to a sewerage system is regulated plumbing work and must be undertaken by a registered or licensed plumber.

Building surveyors are not required to seek a Plumbing Compliance Certificate for the swimming pool recirculation and filtration pipe work, except for the following circumstances:

- if the swimming pool backwash piping to the sewerage system is made below-ground, a VBA drainage inspection must be made available and compliance certificate must be given; or
- if the swimming pool backwash piping connection to an above-ground sanitary drain system is to the value of \$750 or more, a compliance certificate must be given.



There are no Deemed to Satisfy provisions for the drainage of swimming pools under the NCC for Volume One performance requirements of G1P1 and Volume Two performance requirements of H2P4 therefore, a performance solution is required for the drainage of swimming pools and spas.

Electrical Considerations

External faults, distribution system load current in the soil, telecommunication system voltages and lightning discharges can cause voltage differences. Equipotential bonding is required to minimise the risks associated with the occurrence of voltage differences between exposed conductive parts of electrical equipment and extraneous conductive parts.

When planning the swimming pool construction, pool builders must be aware of the requirement for equipotential bonding. (Refer to AS/NZS 3000-2018 Electrical Installations -known as the 'Wiring Rules').

The electrician should attend site while the reinforcing is still exposed and before concrete is poured or sprayed so they can carry out the required electrical work and testing. Where bonding is required, it shall be provided to any fixed conductive material within 1.25 m from the edge of the water, such as pool ladders, diving boards, conductive fences, pipework and reinforcing metal in a concrete slab.

If an Occupancy Permit is going to be issued by the RBS that includes the swimming pool and barrier, a Certificate of Compliance (within the meaning of Division 3 of Part 3 of the Electricity Safety Act 1998 for electrical work) is required for the equipotential bonding, as required by Section 44 of the Electricity Safety Act.

Performance Solutions

Any solution that is proposed must comply with the NCC the Volume One performance requirements of VIC G1P2 (Victorian Variation) and Volume Two performance requirements of H7P1, H7P2, must not provide a level of safety that is less than that provided by the 'deemed-to-satisfy' requirements of AS1926.1, .2 and .3, as appropriate.

Electronic access to the swimming pool area may be provided using a swipe card or proximity card. These cards must only allow the access to be unlocked when held at least 1.5 m above the finished surface.

In the event of total power and battery failure, access to the swimming pool area must be blocked by causing the gate to automatically close and self-latch. A manual override should be included in the performance solution to allow an adult to access the swimming pool area in an event of an emergency, once the access has automatically latched.



Related Documentation

- Building Act 1993
- Building Regulations 2018
- Plumbing Regulations 2018
- Electrical Safety Act 1998
- National Construction Code 2022-2049
- AS1926.1 – 2012 Swimming Pool Safety, Part 1: Safety Barriers for Swimming Pools
- AS1926.2 – 2007 Swimming Pool Safety, Part 2: Location of Safety Barriers for Swimming Pools
- AS1926.3 – 2010 Swimming Pool Safety, Part 3: Water Recirculation Systems
- AS1288 – 2006 Glass in Buildings - Selection and Installation
- AS/NZS 3000 – 2018 Electrical Installations
- Building Practice Note SP 01: Swimming Pools, Building standards and safety requirements
- Building Practice Note PW 02 | Protection of Work Process
- Building Practice Note PW 03 | Protection of Public

List of Amendments

- Update of NCC references to align with the new 2022 referencing system
- Additional information boxes added for further guidance.
- Minor changes to improve readability.
- Update format and content review.

Document history

Sector	Building
Category	Swimming Pools
Topic	Swimming pool barriers and other requirements
Document number	02
Version	2.0
Superseded	<ul style="list-style-type: none"> • Version 1.0, published June 2021.
Published	20 April 2023

Contact Us

If you have a technical enquiry, please email technicalenquiry@vba.vic.gov.au OR plumbingtechnicaladvice@vba.vic.gov.au or call 1300 815 127.

Victorian Building Authority

Goods Shed North
733 Bourke Street
Docklands VIC 3008

www.vba.vic.gov.au



Copyright

© April 2023 Victorian Building Authority (VBA).

This Practice Note has been prepared and published by the VBA for general educational and information purposes only. This publication must not be copied, reproduced, published, adapted, or communicated by any person without the VBA's prior written consent or as permitted by the Copyright Act 1968 (Cth). The VBA makes no warranties or representations whatsoever about the accuracy, reliability, suitability, completeness or authenticity of any information or material contained in this resource. Any use or reliance on such information is at a person's own risk. The VBA accepts no liability whatsoever for any direct, indirect, or consequential loss or damage any person may suffer arising out of or in connection with the access or use of this resource (including any third-party material included in this resource).